

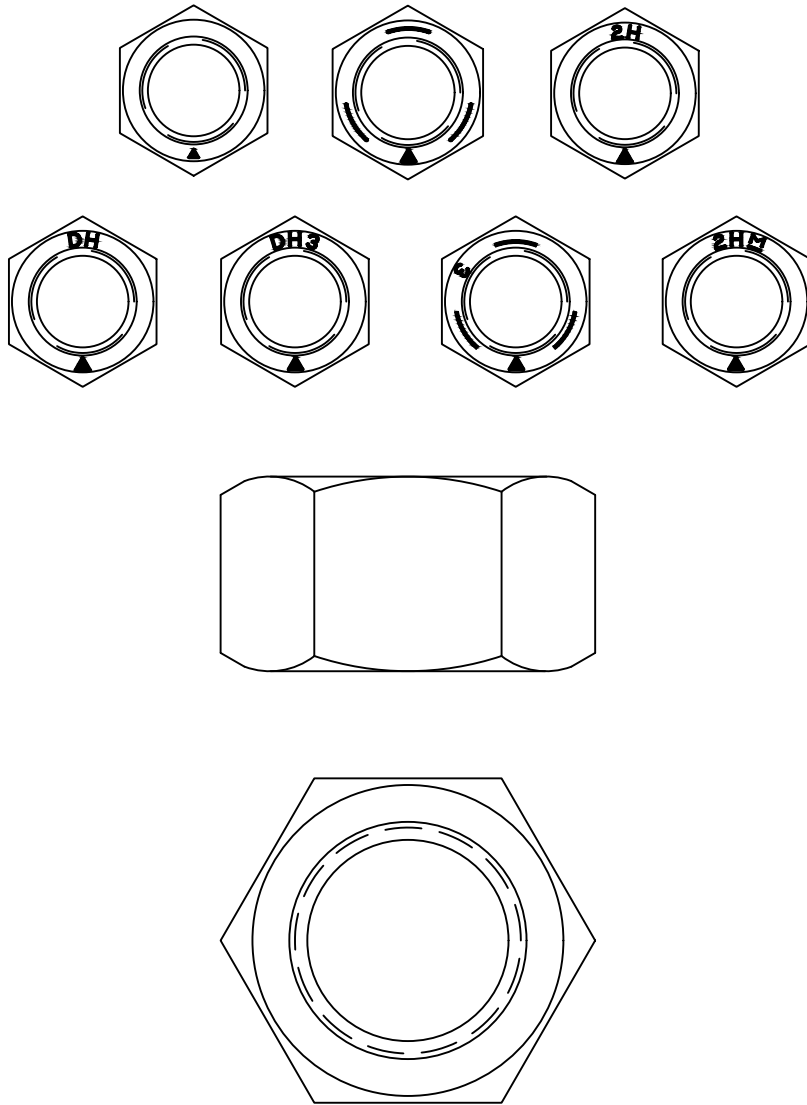

DWG/DESSIN NO.: HVY Hex Nut	THIS DRAWING SUPERSEDES ANY PRINT DATED PRIOR TO: CE DESSIN REMPLACE TOUTE COPIE DATÉE ANTERIEUREMENT:	REPORT ALL ERRORS TO SUPERVISION. RAPPORTER TOUTE ERREUR À LA DIRECTION.																																				
UNLESS OTHERWISE SPECIFIED TOLERANCES ARE: SAUF MENTION CONTRAIRE LES TOLERANCES SONT:	SURFACE FINISH JJ inch / FINI DE SURFACE JJ pouce <table border="1"> <tr> <td>125 ✓ MILLING, DRILLING 63 FRAISAGE, PERÇAGE</td> <td>16 ✓ HONING 8 RODAGE À LA PIERRE</td> </tr> <tr> <td>63 ✓ TURNING, BORING 32 TOURNAGE, ALÉSAGE</td> <td>8 ✓ POLISHING & LAPPING 4 POLISSAGE & RODAGE</td> </tr> <tr> <td>32 ✓ GRINDING 16 RECTIFICATION</td> <td></td> </tr> </table>	125 ✓ MILLING, DRILLING 63 FRAISAGE, PERÇAGE	16 ✓ HONING 8 RODAGE À LA PIERRE	63 ✓ TURNING, BORING 32 TOURNAGE, ALÉSAGE	8 ✓ POLISHING & LAPPING 4 POLISSAGE & RODAGE	32 ✓ GRINDING 16 RECTIFICATION		<table border="1"> <thead> <tr> <th>DATE</th> <th>SYM.</th> <th>MODIFICATIONS/REVISIONS</th> <th>DESS.</th> <th>VER.</th> </tr> </thead> <tbody> <tr> <td></td> <td>A</td> <td></td> <td></td> <td></td> </tr> <tr> <td></td> <td>B</td> <td></td> <td></td> <td></td> </tr> <tr> <td></td> <td>C</td> <td></td> <td></td> <td></td> </tr> <tr> <td></td> <td>D</td> <td></td> <td></td> <td></td> </tr> <tr> <td></td> <td>E</td> <td></td> <td></td> <td></td> </tr> </tbody> </table>	DATE	SYM.	MODIFICATIONS/REVISIONS	DESS.	VER.		A					B					C					D					E			
125 ✓ MILLING, DRILLING 63 FRAISAGE, PERÇAGE	16 ✓ HONING 8 RODAGE À LA PIERRE																																					
63 ✓ TURNING, BORING 32 TOURNAGE, ALÉSAGE	8 ✓ POLISHING & LAPPING 4 POLISSAGE & RODAGE																																					
32 ✓ GRINDING 16 RECTIFICATION																																						
DATE	SYM.	MODIFICATIONS/REVISIONS	DESS.	VER.																																		
	A																																					
	B																																					
	C																																					
	D																																					
	E																																					
FRACTIONS DECIMALS ANGLES ±1/64 ±0.004 ±0°-15'	AS FORGED ✓ ON ALL SURFACES UNLESS OTHERWISE SPECIFIED SUR TOUTES SURFACES SAUF MENTION CONTRAIRE																																					
NOTES:																																						



MATERIAL/MATÉRIAU:	CAUTION - ATTENTION BEFORE STARTING, READ ALL NOTES. AVANT DE DÉBUTER, LIRE LES NOTES. DO NOT SCALE DWGS, WORK TO DIMS. TRAVAILLER SELON LES COTES SEULEMENT. ALL DIMENSIONS GIVEN IN INCHES. TOUTES DIMENSIONS EN POUÇES.	DESIGN./CONCEPT. INFASCO	DESCRIPTION: INFASCO HVY Hex Nut	
TREATMENT/TRAITEMENT: SAE J995 2 ASTM A194 2H - 2HM ASTM A563 DH - DH3 - C - C3		DRWN./DESSINÉ GL		
	 INFASCO MARIEVILLE, QUÉBEC, CANADA 06-17	APPR. BY/PAR	MACH.:	REFER. TO/A:
		SCALE/ÉCHELLE	FILE DOSSIER	DWG/DESSIN NO.:
		SHEET FEUILLE	OF DE	HVY Hex Nut